

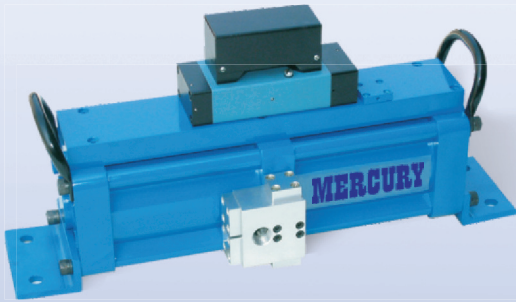

Leadership through innovation



BOOSTER UNIT

OPTIONAL ACCESSORIES

- 1) Outlet hand slide valve.
- 2) Safety / Relief valve.
- 3) High Pressure Regulator with gauge.

MAX. INLET AIR CONSUMPTION (NLPM)

MODEL No.	INLET AIR PRESSURE			
	4	6	8	10
AB 100-2	925	1500	2000	2400
AB 160-2	1800	2300	2800	3750
AB 160-3	1800	2300	2800	3750
AB 160-7	600	1000	1600	2350

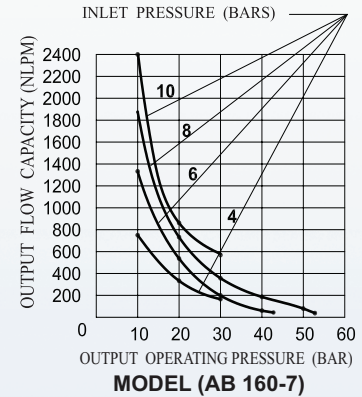
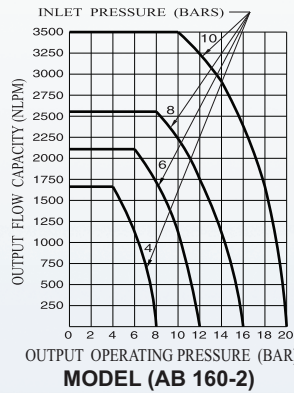
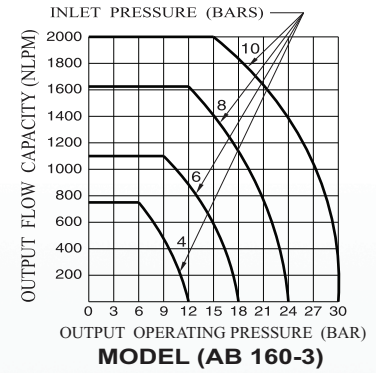
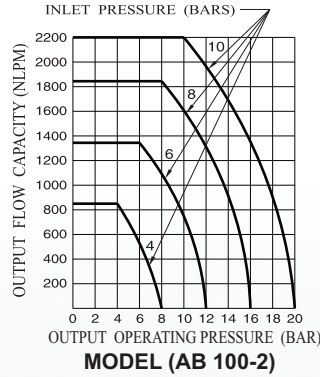

(AB 160-2T40)



(AB 100-2T5)

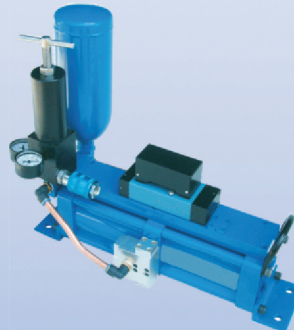

(AB 100-2T2)

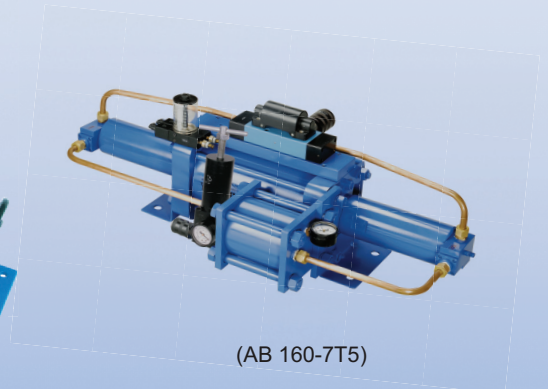

(AB 160-7T5)

BOOSTER UNIT WITH AIR RECEIVER

MODEL	SIZE	
	BOOSTER MODEL	AIR RECEIVER (LITRES)
AB100-2T2	AB100-2	2
AB100-2T5	AB100-2	5
AB100-2T10	AB100-2	10
AB100-2T20	AB100-2	20
AB160-2T10	AB160-2	10
AB160-2T20	AB160-2	20
AB160-2T40	AB160-2	40
AB160-3T20	AB160-3	20
AB160-3T40	AB160-3	40
AB 160-7T1	AB 160-7	1
AB 160-7T2	AB 160-7	2
AB 160-7T5	AB 160-7	5
AB 160-7T10	AB 160-7	10

ITEMS INCLUDED IN STANDARD SUPPLY

- Inlet hand slide valve.
- Outlet hand slide valve.
- Safety / Relief valve. *
- High Pressure Regulator with gauge
- Tank Pressure gauge.
- Drain valve.
- Autolube Pump *

OPTIONAL ACCESSORIES

- Wheel trolley.
- FRL unit.
- Additional outlet with high pressure regulator and hand slide valve.

* Not included in AB160-7 models.